

Features

- Strap devices, Axial leaded
- Low switching temperature
- Protection for NiCd/NiMH rechargeable battery packs, Li-ion /Polymer Li-ion battery
- Lead-free devices, the right logo is lead-free mark of wayon
- Agency recognition: UL、TUV



Product Dimensions (mm)

A		B		C		D		E		F	
Min.	Max.	Min.	Max.	Min.	Max.	Min.	Max.	Min.	Max.	Min.	Max.
20.9	23.1	4.9	5.5	-	0.8	4.0	6.0	4.0	6.0	3.9	4.1

Chip Size: 5*12mm

Leads: Pure Nickel, 1/2H

Solder: Lead-free

Tape: Polyester

Marking: LV230

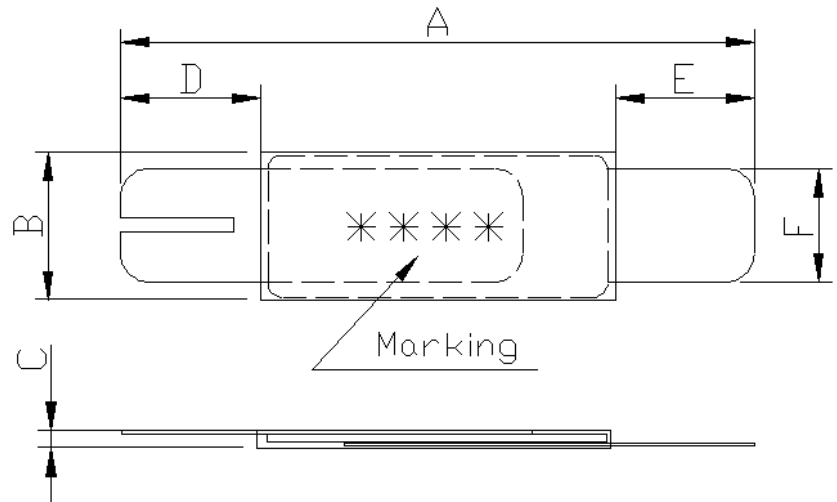

Electrical Characteristics

Maximum Electrical Rating

- Operating Voltage: 12Vdc
- Interrupt Current:100A

IH	IT	Vmax	I _{max}	Pd	Ttrip	Rmin	Rmax	R1max
(A)	(A)	(V)	(A)	(W)	Current (A) Time (S)	(Ω)	(Ω)	(Ω)
2.3	5.0	12	100	1.4	11.5 5.0	0.012	0.018	0.036

Package Information

Bulk, 1000pcs per bag.

维安条状 PTC 的注意事项

Cautions for Strap PTC

1. 请在规格书规定的最大电压和最大电流下使用，超出 PTC 最大电压或最大电流规格值的操作，可能会导致 PTC 出现电弧，阻值升高，甚至烧片。
Operation beyond the maximum voltage or current may result in device damage and possible electrical arcing or flame.
2. 规格书所规定的各温度下的 Hold current 均是 PTC 经过一次点焊后的常规性能，PTC 能够在不同温度对应的电流条件下保持 1 小时。该电流并不是该型号 PTC 能够适用的长期充电或放电电流的条件。
The Hold current specified at different temperatures in the datasheet is the conventional performance of after one spot welding. PTC can hold 1 hour at the current corresponding to different temperatures. But this current is not the condition that PTC can charging or discharging current for long time.
3. PTC 为热敏元件，对环境温度比较敏感，建议在 PTC 周围不要设计热源元件，尽量减少外部热源的影响。
PTC is thermal sensitive device. It is recommended that no heat source devices be designed to around in order to reduce the outside heat source impact .
4. 条状 PTC 产品是为点焊或注塑封装形式，点焊位置不宜直接接触 PTC,注塑温度不宜高于 250℃。
The packing of Strap PTC is spot-welding. The spot welding position should not contact PTC directly.
5. PTC 组装或应用过程中,所使用到的各类注塑料、单组份、双组份固化胶粘剂、硅胶，需要对注塑料胶料等材料牌号以及应用参数（如温度、时间等）进行验证，以确保产品及工艺的匹配性，确认不会影响 PTC 性能之后方可使用。
When assembling and applying PTC, the material mark and application parameters (Temperature, Time, and etc.) of all injection or plastic materials, like adhesives, silica gels and etc. should be verified to ensure the consistency between the products and the processing technology. Only it is confirmed that would not influence PTC then can be used.
6. PTC 组装或使用过程中，不建议使用洗板水或其他清洗剂进行清洗。如必须使用，需要验证各类清洗剂、洗板水以及溶剂的适用性，确认不会影响 PTC 性能之后方可使用。已知对 PTC 有影响的化学药品包括但不限于醚类、苯类、酮类以及脂类等较强溶解性、破坏性的有机化合物。清洗后将产品放置于敞开的环境中至少 24 小时，将残留的溶剂进行充分的挥发。
When assembling and applying PTC, it is not recommended that using washer water or other cleaner to clean PTC. If it is required, it is necessary to verify the applicability of various cleaner, washer water and solvents, it is also confirmed that they will not affect the PTC performance . Chemicals that are known to have an effect on PTC include, but are not limited to, highly solubility and destructive organic compounds such as ethers, benzenes, ketones, and lipids. Placing the product in open environment for at least 24 hours to volatilize the residual solvents.
7. 装配过程中，避免用暴力砸、挤、压、拉、扭、刺等方式作用 PTC 本体，以免引起 PTC 性能衰减。
Please do not smash, clamp, pull, dent, twist and etc. to PTC during assembling process to avoid the performance degradation.
8. PTC 是二级保护元件，仅用于零星、意外过流或过温等情况，持续或重复的故障情况不得使用。
PTC is a secondary protector, which is only can be used as sporadic, accidental over-current or over-temperature, the continuous or repeated failure can not use PTC.
9. 不建议将 PTC 安装在空间受到限制的环境中，这将会抑制其 PTC 性能。
PTC is not recommend installation in space-constrained environments, which can inhibit its performance